

## Switches

# PPS-TH51

**Solid state high voltage, high current switch for pulsed power applications**

### General Applications:

- Thyatron replacement
- Food sterilization
- Medical systems
- Radar power supplies
- Security systems
- High power lasers
- Beam accelerators
- Seismic research
- Environmental systems (De-NOx/SOx filters)

### Features :

- DC voltage capability up to 30kV
- High non-repetitive pulse current up to 20kA
- High repetition rate up to 1300Hz
- High di/dt capability up to 10kA/ $\mu$ s
- Reverse conducting with monolithic integrated free wheel diode
- Immune to vibration as compared to thyatron
- Air or liquid cooling
- Ready to use with integrated power supply, monitor and driving system

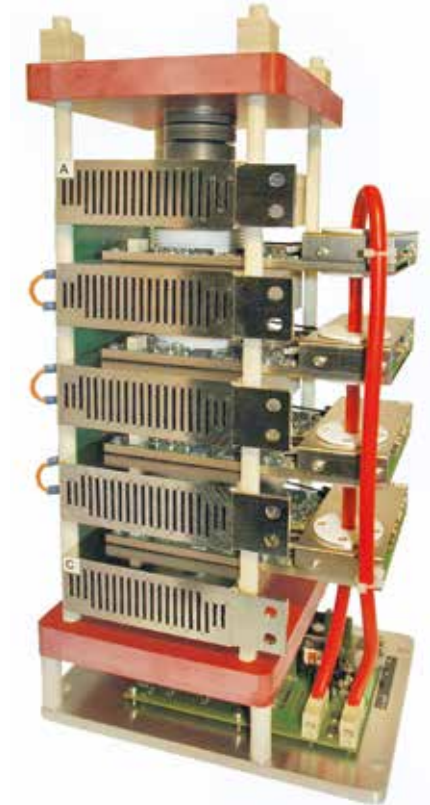

## Technical specification of 10.5kV switch AA-10368-004

Parameter	Symbol	Remarks	Min.	Typ.	Max.	Unit
Operating voltage	V	Working voltage for 100 FIT (Element)	-	-	10.5	kVDC
Pulse current	I	Single pulse (10 $\mu$ s)	-	-	20	kA
Current rise rate	di/dt		-	-	10	kA/ $\mu$ s
Repetition rate	f	Working current 1200A	-	-	1300	Hz
Reverse leakage current	I <sub>leak</sub>		-	-	20	mA
Number of levels	n		-	4	-	pcs
Cooling system	-	forced air			4	m <sup>3</sup> /sec
Operating temperature			5	-	60	°C
Storage temperature			-25	-	85	°C
Logic power supply	V <sub>Logic</sub>		48	-	72	VDC
Power consumption logic	P	4 Elements @1300Hz	-	-	80	W

### Diagram

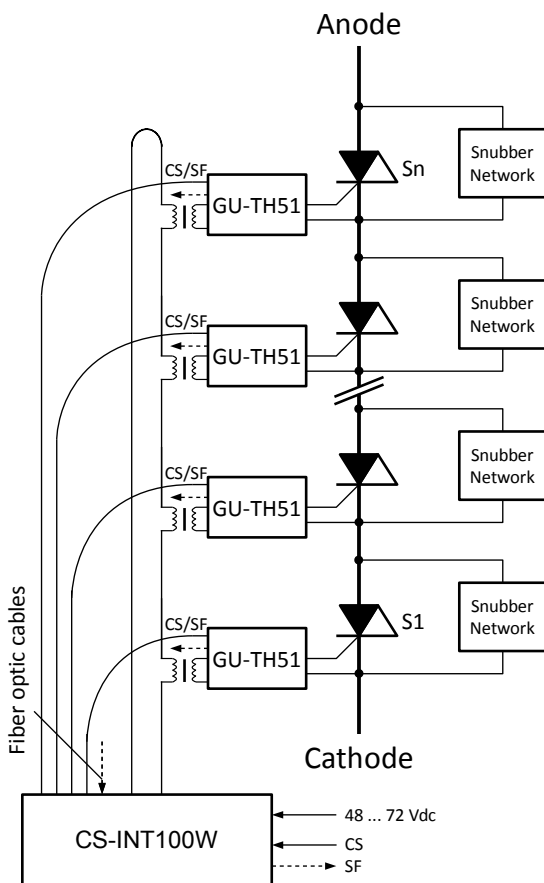

### Details



Power Supply / Light Interface: CS-INT100W



Gate Unit: GU-TH51

Order code	Description	Version
AA-10368-002	PPS-TH51-2-08F4599	PPS with AZ-51 element, 2-level
...	...	...
AA-10368-010	PPS-TH51-10-08F4599	PPS with AZ-51 element, 10-level
AA-10368-102	PPS-TH51-2-0845F0003	PPS with adapted standard element, 2-level
...	...	...
AA-10368-110	PPS-TH51-10-0845F0003	PPS with adapted standard element, 10-level