

Customer name: Pankaj Electronics

Type2 32A/480V AC 5m



版本号 Ver	更改通知单号 ECN	更改标记 MARK	描述 DESCRIPTION	日期 DATE	签字 APP	校对 CHK

Type II  
2-IIe

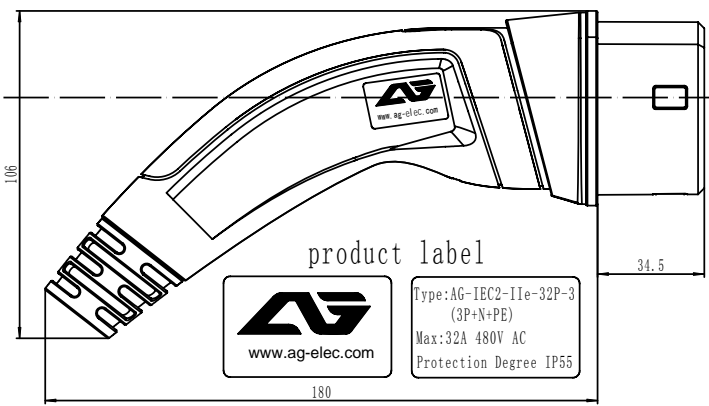
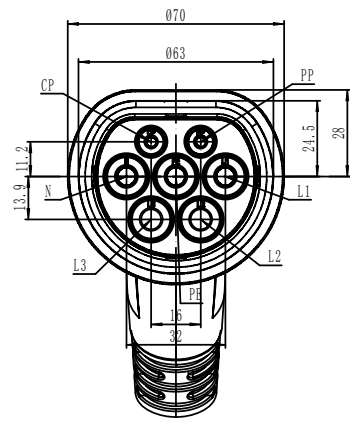

Technical parameters  
Current and Voltage : 32A 480V AC  
Signal current : 2A 30V  
Protection Degree : IP55

Cable specification

Function	32A 480V AC
L1 (1)	6 mm <sup>2</sup> Brown
L2 (2)	6 mm <sup>2</sup> Black
L3 (3)	6 mm <sup>2</sup> Grey
N (4)	6 mm <sup>2</sup> Blue
PE (5)	6 mm <sup>2</sup> Yellow-green
CP (6)	0.5 mm <sup>2</sup> White
PP (7)	With no function

棕  
黑  
灰  
蓝  
黄绿  
白

mode of connection

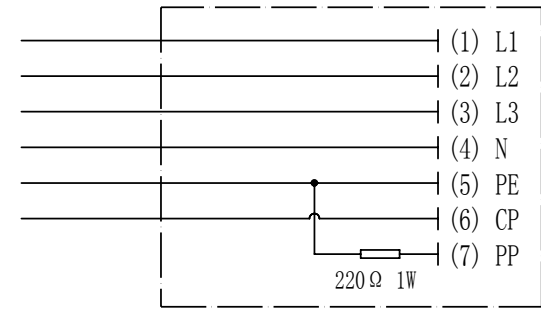

橙色包胶 Black shell  
orange rubber coating

IEC 62196-2 (2-IIe)

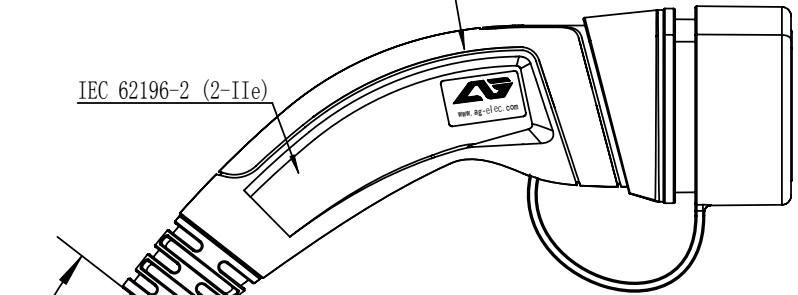

黑色TUV线缆  
H07BZ5-F 5\*6mm<sup>2</sup>+2\*0.5mm<sup>2</sup>  
Black TUV overall cable

OLR32160-BK

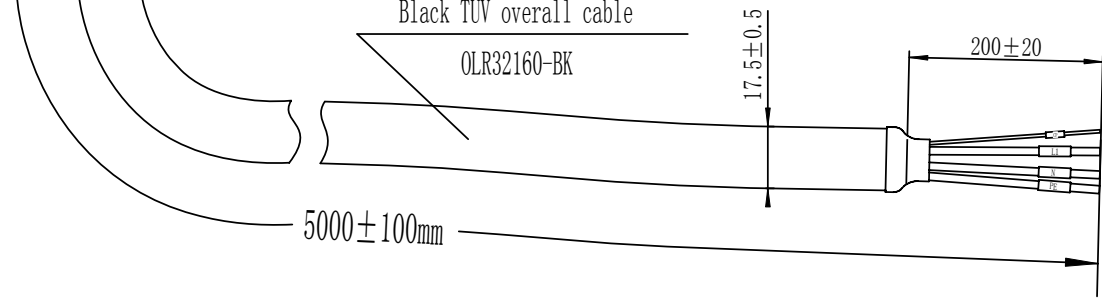

32A 3P+N+PE+PP+CP

Type II ,was designed according to the standard of IEC 62196-2 2016 sheet 2-IIe

The static resistance is 220 ohm

Charging cable 5000mm 5\*6mm<sup>2</sup>+2\*0.5mm<sup>2</sup> Black TUV overall cable

图样标记 DWG. SYM	S A	投影标记 PROJ. SYM		AG ELECTRICAL Technology Co. Ltd			
材料 MATL	Specifications			重量 WEIGHT	名称 NAME		
设计 DESIGNED	日期	审核 CHECK	日期	标准化 STDCHECKED	日期	图号 DRAW NO.	纸幅 SIZE
校对 CHECKED	日期	工艺 PROCESS	日期	批准 APPROVED	日期	品号 PART NO.	比例 SCALE
						第 X 张	共 X 张
						SHEET X OF X	